

## Main specification parameter for D10N Track Carrier Roller

Brand	Model	Product Name	Part Number	Assembly Quantity	Weight
Caterpillar	D10N	Carrier Roller	7T0682	2	139 Kg



## Compatible Equipment Models: 7T0682

D10N	D9L
------	-----

## Product Details

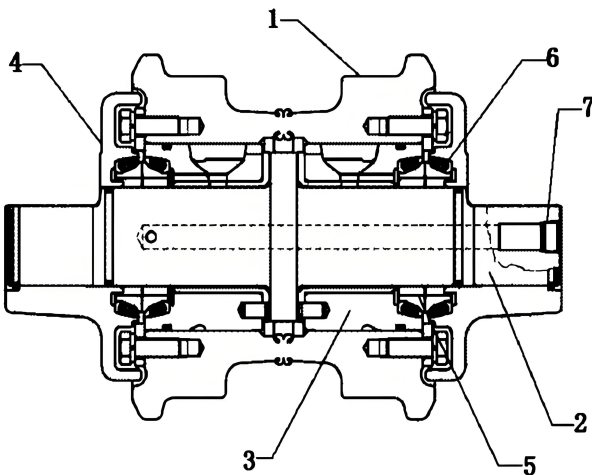
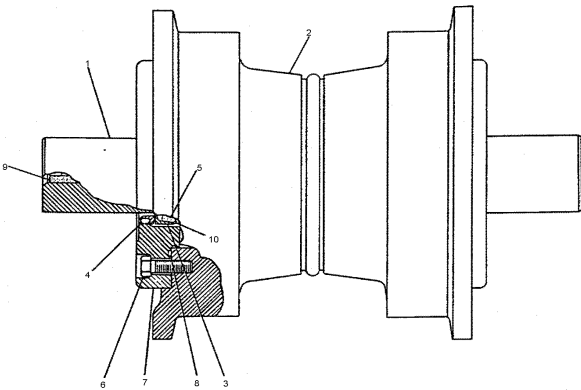

Product Name	Carrier Roller
Part Number	7T0682
Quantity per Equipment	2
Weight	139KG
Origin	United States
Brand Name	STONE
Model	D10N
Price	Negotiable
Packing Details	Standard Export Packing
Delivery Time	0-30 Days
Payment Term	L/C, T/T
Price Term	FOB, CIF, CFR
Supply Capacity	50,000 PCS/Month
Minimum Order Quantity	1 PC
Material	High Quality Steel
Technology	Precision Machining
Surface	Treatment Anti-Corrosion Coating
Quality	Original Factory Standard
Warranty Time	12 Months or 2000 Hours
After-Sales Service	Full Support, Online Service
Color	Standard Caterpillar Yellow or Customizable
Application	Bulldozer
Customizable	including customized materials, surface treatment and specifications

# Track Carrier Roller

7T0682

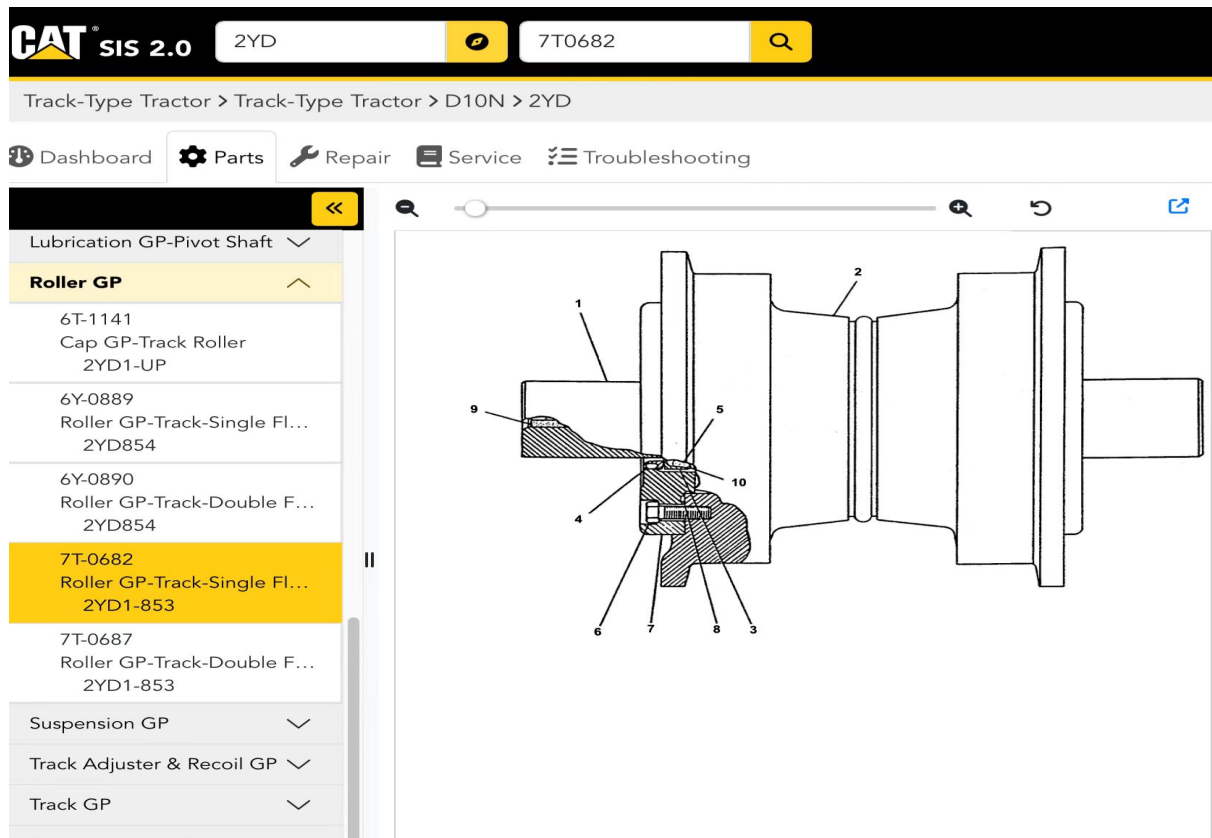

## STONE: Construction machinery parts expert in China



We are committed to providing a variety of parts including bulldozers, excavators and wheel loaders for well-known brands such as Carter and Komatsu. Our product line covers a full range of OEM parts, such as Track Chain, Track Rollers, Sprocket, Excavator Buckets, Blades, Excavator Cylinders, Swing Circles, and various electrical and hydraulic components to ensure that our customers' stringent requirements for quality and performance are met.



Stone (Shanghai) Engineering Machinery Co., Ltd. is a leading supplier of engineering machinery parts, focusing on providing high-quality parts for mining companies. Since its establishment in 2004, we have been based in Shanghai, China, and have built our own brand STONE, becoming a trusted choice in the industry.